

Modular

eléctrico / electric



El horno modular Salva es reconocido en los sectores de panadería, pastelería y pizzería por su calidad de cocción, flexibilidad y polivalencia.

Se adapta a las necesidades productivas del cliente, ya que al estar formados por módulos o cámaras independientes apilables, cada cliente puede montar el horno a su medida. Además el hecho de tener módulos independientes hace que sean muy polivalentes, ya que permiten cocer diferentes tipos de producto en cada módulo.

La característica de estos hornos que los hace únicos reside en su sistema de distribución de calor. Un conjunto de ladrillos refractarios cerámicos atravesados por resistencias eléctricas, situados en techo y suelo, garantizan un reparto de calor uniformen toda la cámara, dotando a panes, pasteles y pizzas de un sabor, textura y aspecto únicos.

Salva modular ovens are renowned in the bakery, cakemaking and pizzeria sectors thanks to their quality of cooking, flexibility and range of options.

They adapt to the production requirements of each customer, since the independent, stackable chambers or modules allow the oven to be assembled as desired. Moreover, these independent modules give the ovens a high range of options, as different types of products can be cooked in each module.

The characteristic which makes these ovens unique is their heat distribution system. A series of refractory ceramic bricks crossed by electrical resistances situated in the upper and lower sections ensure the uniform distribution of heat throughout the chamber, hence giving bread, cakes and pizzas a unique taste, texture and appearance.

salva

**PANADERIA
BAKERY**

Artesana /
Artisan

Punto caliente /
Bake-off shop

Semi-industrial /
Semi industrial

**PASTELERÍA
PASTRY**

Artesana /
Artisan

**PANADERIA Y
PASTELERIA
BAKERY AND
PASTRY**

**Hornos
Ovens**

Labe

Eolo

Kwik-co

Kwik-co Gas

Boutique

Kwik-co & Easy load

Metro

Modular

Sirocco

Elecsol

**Fermentadoras
Proofers**

Armario AR /
AR cabinet

Cámara AF /
AF chamber

Armario Iverpan /
Iverpan cabinet

Armario Iverpan /
Iverpan cabinet
BASIC

Cámara FC /
FC chamber
BASIC

Cámara FC /
FC chamber
LUXE

**Abatidores
congeladores
Blast chillers**

Ultra Artic

**Máquinas
Machines**

**Accesorios
Accessories**

**PIZZA
Hornos
Ovens**

Modular EM

Modular E

Modular EMD

Modular NXM

Modular NXE

Horno / Oven
4-30 & 8-30

**Condiciones
de venta
General sales
conditions**

**Plazos
de entrega
Delivery
periods**

**Simbología
Simbology**

Modular E

eléctrico / electric

Características técnicas / Technical characteristics



TIPO / TYPE	Kw	Kcal/h	Fases Phases	V	A	Hz	Volumen / Volume dm ³
MODULO E-20 DECK E-20	7,8	6.800	3N~	230/400	21,6 / 11,7	50/60	166
MODULO E-20+V DECK E-20 + S	9,2	6.800	3N~	230/400	21,6 / 11,7	50/60	166
MODULO E-30 DECK E-30	9,8	8.500	3N~	230/400	27,0 / 14,7	50/60	249
MODULO E-30+V DECK E-30+S	11,20	8.500	3N~	230/400	27,0 / 14,7	50/60	249
ESTUFA E+H PROOFER E+H	1	900	1N~	230	5	50/60	3.024

Dimensiones / Dimensions

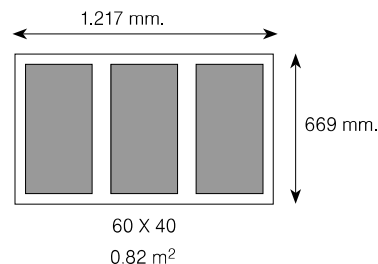
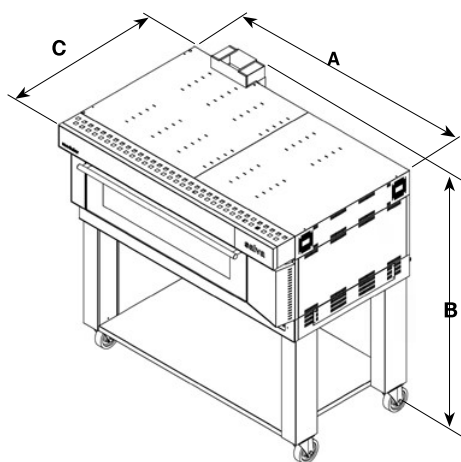

Módulo Pastelero
Downward & outward opening deck

E	A mm	B mm	C mm	Peso / Weight Kg	Capacidad / N° Trays
MODULO E-20 DECK E-20	1.717	315	1.073	168	3 (60 X 40)
MODULO E-20 CON VAPOR DECK E-20 + STEAM	1.717	315	1.073 (*)	236	3 (60 X 40)
MODULO E-30 DECK E-30	1.717	415	1.073	208	3 (60 X 40)
MODULO E-30 CON VAPOR DECK E-30 + STEAM	1.717	415	1.073 (*)	256	3 (60 X 40)
ESTUFA E+H PROOFER E+H	1.717	704	924	127	3 (60 X 40) X 5 Alturas / Levels
BASE E BASE E	1.717	150	924	65	-
ENCIMERA E TOP E	1.717	165	1.088	45	-

(*) El fondo se debe aumentar en 23 mm. debido a los tubos de desagüe.
(*) The depth should be increase in 23 millimetres for the pipes of outlet

salva

PANADERIA
BAKERY

Artesana /
Artisan

Punto caliente /
Bake-off shop

Semi-industrial /
Semi industrial

PASTELERÍA
PASTRY

Artesana /
Artisan

PANADERIA Y
PASTELERIA
BAKERY AND
PASTRY

Hornos
Ovens

Labe

Eolo

Kwik-co

Kwik-co Gas

Boutique

Kwik-co & Easy load

Metro

Modular

Sirocco

Elecsol

Fermentadoras
Proofers

Armario AR /
AR cabinet

Cámara AF /
AF chamber

Armario Iverpan /
Iverpan cabinet

Armario Iverpan /
Iverpan cabinet
BASIC

Cámara FC /
FC chamber
BASIC

Cámara FC /
FC chamber
LUXE

Abatidores
congeladores
Blast chillers

Ultra Artic

Máquinas
Machines

Accesorios
Accessories

PIZZA
Hornos
Ovens

Modular EM

Modular E

Modular EMD

Modular NXM

Modular NXE

Horno / Oven
4-30 & 8-30

Condiciones
de venta
General sales
conditions

Plazos
de entrega
Delivery
periods

Simbología
Simbology